

Motivation for this group of talks

- For a few years, several organizations (AEF, AEM, ASABE, ISO, AgGateway) have been cooperating in the context of the AETC Conference to define how they fit / work together.
- The following three presentations are an introduction to some of the opportunities for collaboration among different segments in agriculture (equipment, chemical, data, regulatory) on matters pertaining to spraying technology and drift, that emerged from the interactions among those groups.
- The intent is to help actors in the industry understand the value of, and need for, consensus-based standards.

The Three Presentations

- Andres: Regulatory and interoperability context, the idea of OK to Spray, and how it can be used.
- Joe: Machine control technologies that can be used to mitigate drift, and the standards that guide them.
- Todd: Identifying needs for enabling adaptive spraying technology, including organizational alignment and consensus standards.



OK to Spray

R. Andrés Ferreyra, Ag Connections, LLC

InfoAg 2016

in St Louis, MO, August 3, 2016



Reporting burden is increasing

- Crop protection regulatory reporting requirements are increasingly burdensome in many regions around the world.
 - Growers may need to report types of seed used, crop protectants and nutrients applied, conditions surrounding field operations, and commodity yield data.
-
- The reporting burden includes a mix of Federal, state, and local regulations, as well as trading-partner-imposed protocols.



Lack of interoperability

Field operation reporting becomes especially difficult and time-consuming given the lack of interoperability among brands and types of machines, crop production input vendors, and the wide range of software programs used by growers and management services, each of which typically uses a proprietary data format and concept definitions.



Not scalable or sustainable

Current context:

- Increasing regulatory burden
- Poor interoperability

Consequence:

It's becoming increasingly likely for growers or applicators to **unknowingly** find themselves out of compliance with a regulation, despite their best stewardship efforts.



AgGateway

- AgGateway North America is a consortium of 240+ companies dedicated to promoting e-business in agriculture since 2005.
- AgGateway emphasizes implementation: it does not create standards where an existing standard can be implemented or expanded.
- AgGateway actively collaborates with a variety of organizations (OAGi, ASABE, AEF, etc.) and is expanding internationally through a global network of regional organizations (e.g., AgGateway Europe.)
- AgGateway was invited to bring its data exchange and standards implementation focus to the regulatory compliance table.

AgGateway North America Collaborative Associations

Updated 2014-11-12

Past Associations

PIDX

RAPID*

CIDX*

WS-I*

OASIS

ANSI ASC X12

*No longer exists

CropLife Canada

CropLife America

Ag-CIO Council

IPSA

AUVSI

GS1 Canada

AgXML

AEF

AEM

NGFA

GS1 US

OAGi

AgGateway

TFI

Departments of Agriculture for several U.S. States

UN/CEFACT

ASABE

ISO

NEEA

USDA

Office of the CIO

F&FAS

NRCS

AFIA

ARA

ASTA

American Farm Bureau

CPDA

AEMP

NCIS

NAAA

USDA	Office of the CIO	F&FAS	NRCS
GIPSA	ARS	RMA	FSA

Government

Standards Group

Industry Association

EPA

AgGateway and interoperability

- AgGateway contains industry segment councils.
- Its Precision Agriculture Council identified **field operations data interoperability** as a major challenge for the industry, chartering multiple projects (SPADE1, SPADE2, SPADE3, PAIL1, PAIL2) to address the problem, based on standards such as ISO11783, ISO19156 and ISO11356.
- Another AgGateway effort, **ADAPT**, seeks to create a common, geopolitical-context-adaptable **object model** to represent field operations data, as well as an **open-source framework** for conversion libraries to **translate** data between the object model and proprietary formats.
 - Common, open-source framework + manufacturer-specific plug-ins

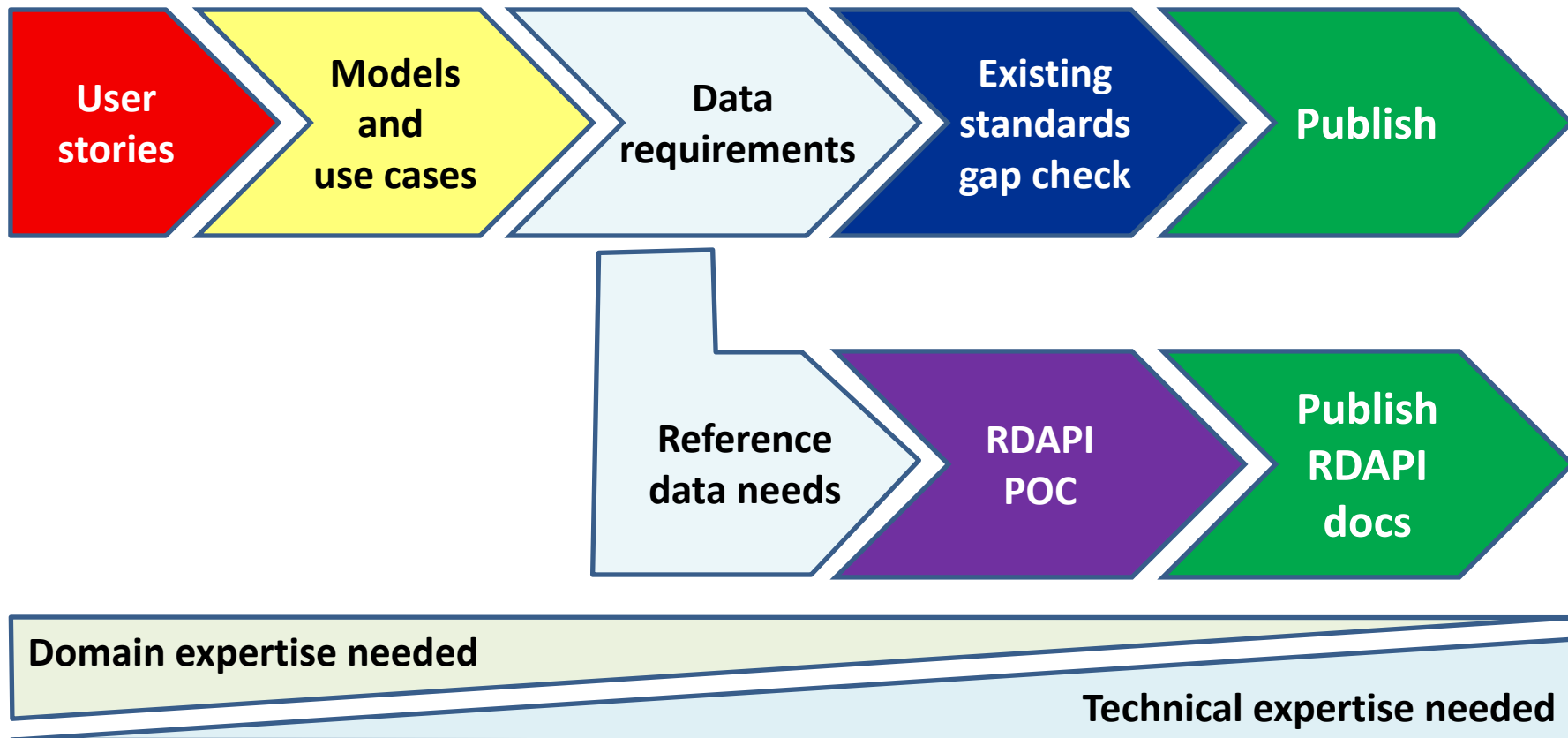

Much of the work in SPADE and PAIL has followed the process shown above:

- User stories were obtained from growers and other subject-matter experts (SMEs.)
- The processes described by the stories were modeled and translated into use cases usable by software companies.
- Data requirements were identified by the SMEs and technical experts working together.
- The technical experts looked for, and proposed solutions for, gaps in existing standards.

Scope of the data exchange in SPADE

Farm Management
Information System
(FMIS)

Mobile Implement
Control System
(MICS)



Covered by
ISO11783-10

Scope of the data exchange in SPADE

Farm Management
Information System
(FMIS)

Mobile Implement
Control System
(MICS)



Farm Management
Information System
(FMIS)

ISO11783-10
does not cover this.

Field Operation - Spraying

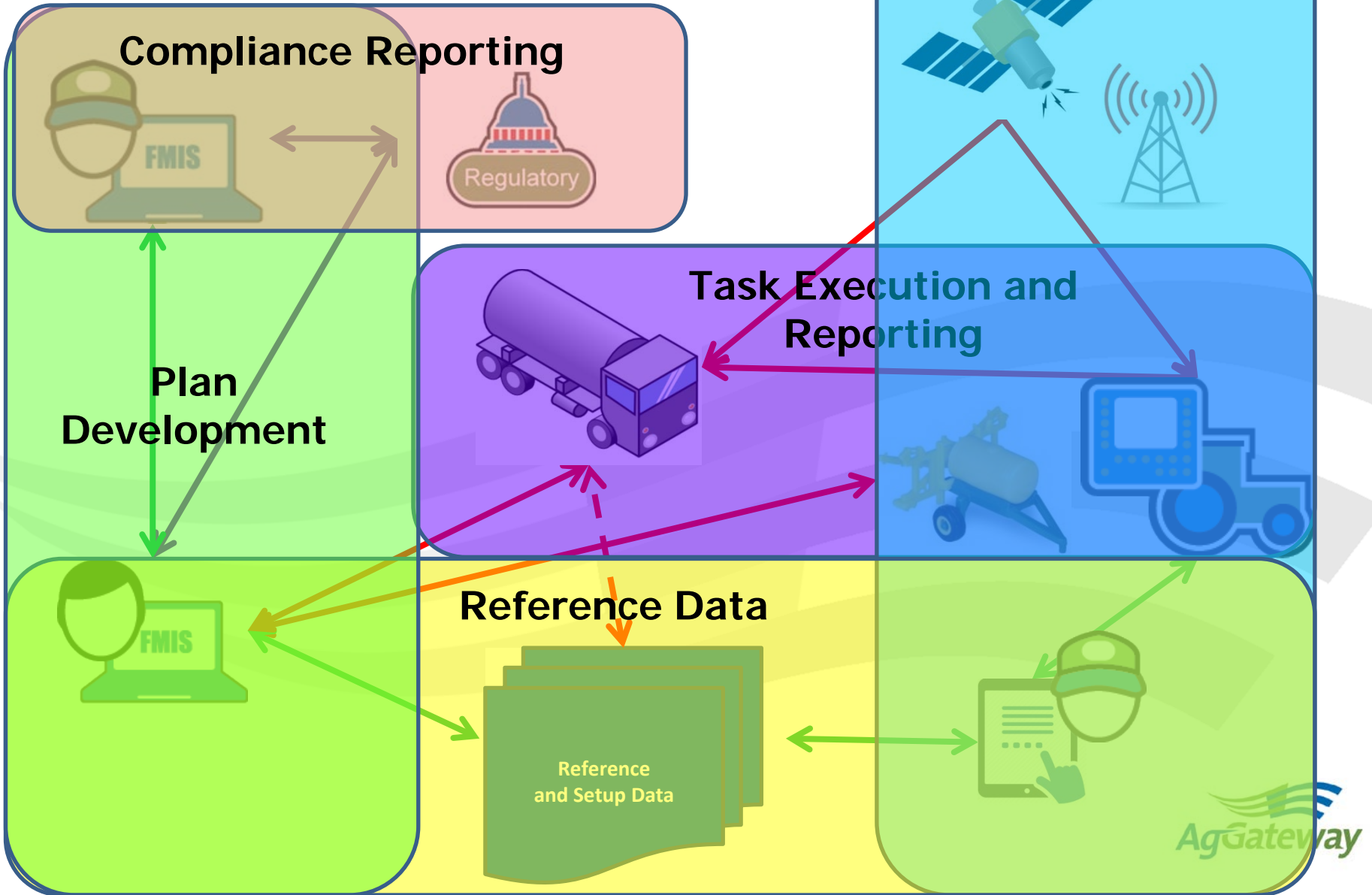

Supporting Standards

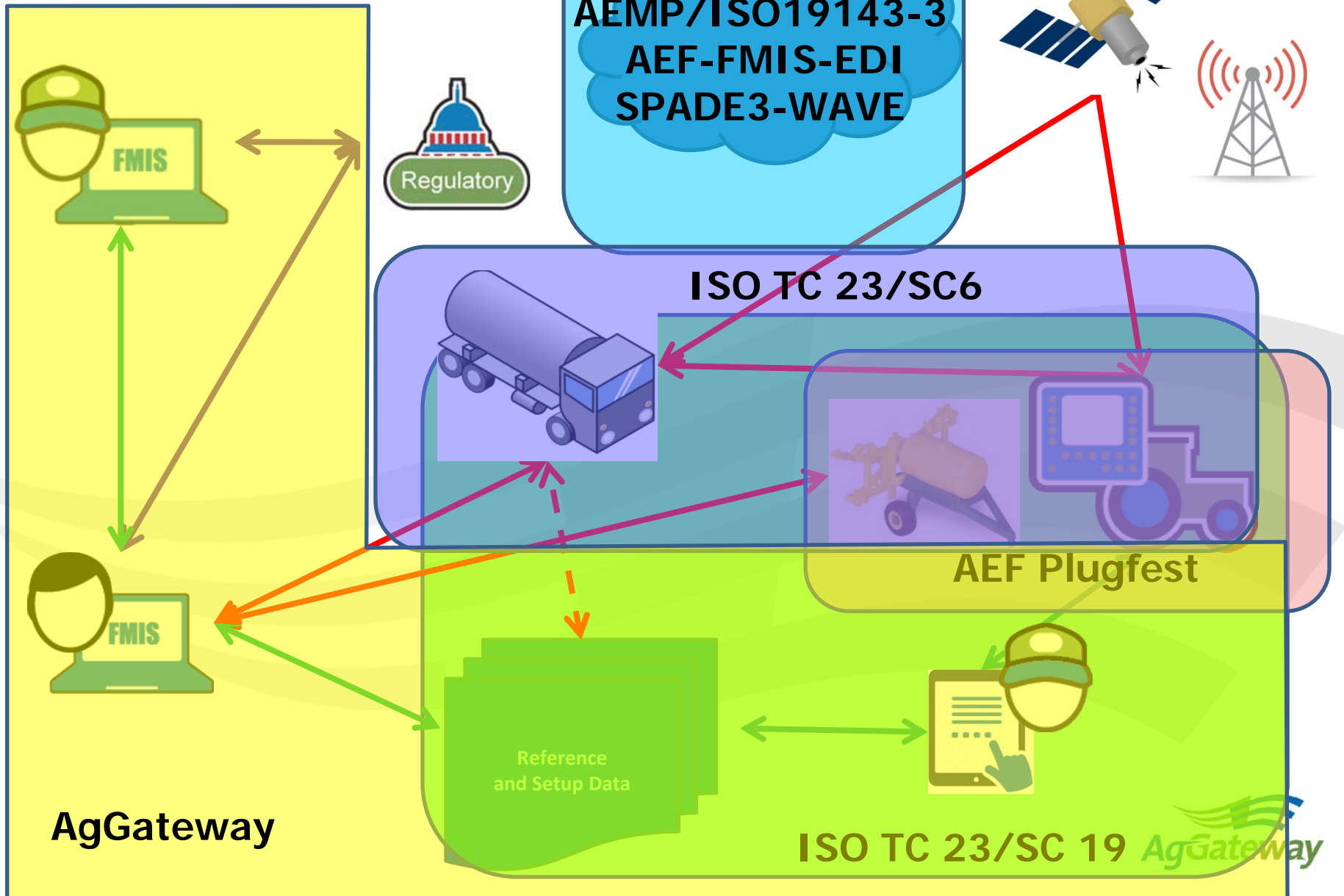

SPADE Contribution: OK to Spray

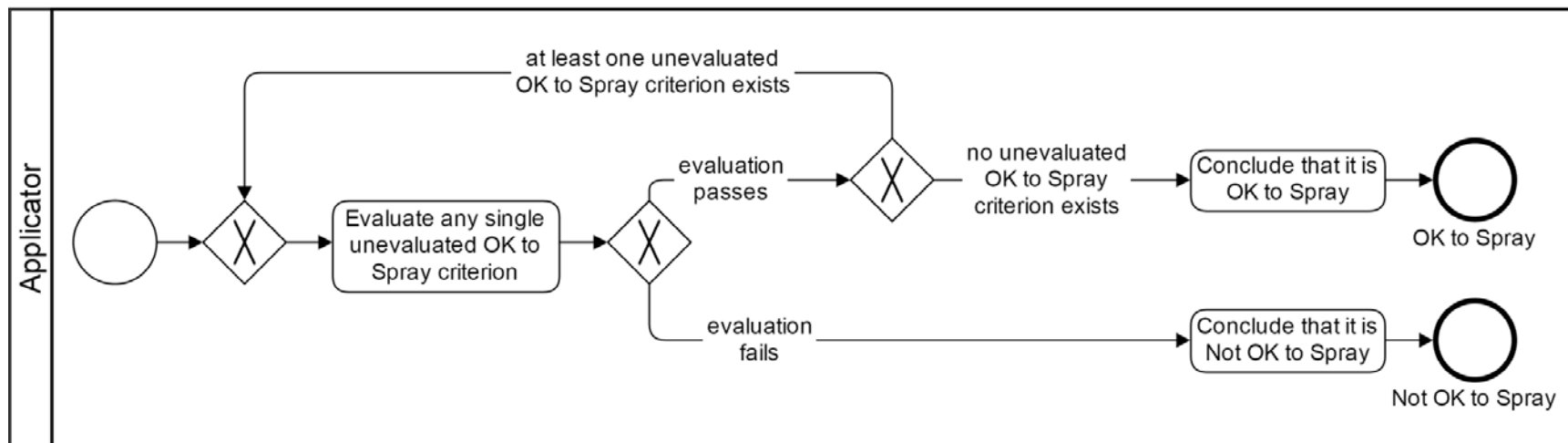

A conceptual contribution emerging from the SPADE projects is “OK to Spray” (OK2S): a **process** where a **participant** in the **application of crop protection products on a field** evaluates, repeatedly as needed during **application planning, preparation, and execution**, whether the **conditions necessary to perform the application** are met.

What's the intent of OK to Spray?

- “OK to Spray” is a proposal for industry and government to standardize how to represent compliance-checking data in field operations.
- The goal is to make it easier for growers and other industry participants to **communicate** and **understand when a field operation can happen**, by determining repeatedly, as necessary during product (or service) application **planning, preparation, and execution**, whether there are any conditions that should prevent the field operation from taking place.

We need standards (they create opportunity)...

- Developing consensus standards around ideas such as OK to Spray would make it easier for the industry to leverage increased interoperability and provide richer solutions for common field operations problems.
- Spray drift is a good example:
 - An OK to Spray standard plus interoperable real-time data sources would enable accurate reporting of compliance or non-compliance. (1)
 - However, it would also enable real-time OK to Spray evaluation and the ability to **prevent noncompliance** by suspending product application under inadequate conditions. (2)
 - Further, it could enable machinery to **dynamically adapt** to changing conditions to **remain OK to Spray** under a wider set of conditions. (3)

Simplified example: applying a RUP

- **Planning** (days leading up to the field operation)
 - Is this product appropriate to the observed problem in the field?
 - Do I have available the correct nozzles & equipment as per the label?
- **Preparation** (Just before the field operation / at the field gate)
 - Are Worker Protection Standard (WPS) postings in place?
 - Has the worker been provided with Personal Protective Equipment (PPE) as per the product label?
 - Have all restricted-entry intervals (REIs) expired on the field?
 - Is the application area downwind of the nearby school?
 - Is the application area downwind of my organic (or any sensitive) crops?
- **Execution** (During the field operation)
 - Is the wind speed low enough to control drift?
 - Is the temperature low/high enough for the application?
 - **Is all product drift staying inside the field boundary?**

How OK to Spray works (e.g., Preparation)

- ✓ • Are Worker Protection Standard (WPS) postings in place?
- ✓ • Has the worker been provided with Personal Protective Equipment (PPE) as per the product label?
- ✓ • Have all restricted-entry intervals (REIs) expired on the field?
- ✓ • Is the application area downwind of the nearby school?
- ✓ • Is the application area downwind of my organic (or any sensitive) crops?

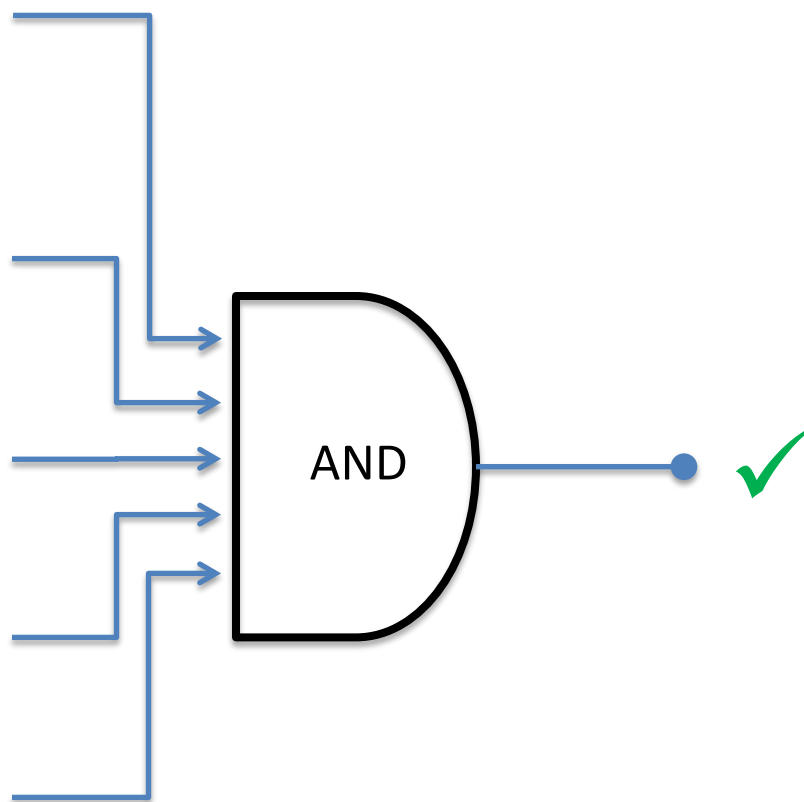

One failed condition → NOT OK to Spray

- ✓ • Are Worker Protection Standard (WPS) postings in place?
- ✓ • Has the worker been provided with Personal Protective Equipment (PPE) as per the product label?
- ✗ • Have all restricted-entry intervals (REIs) expired on the field?
- ✓ • Is the application area downwind of the nearby school?
- ✓ • Is the application area downwind of my organic (or any sensitive) crops?

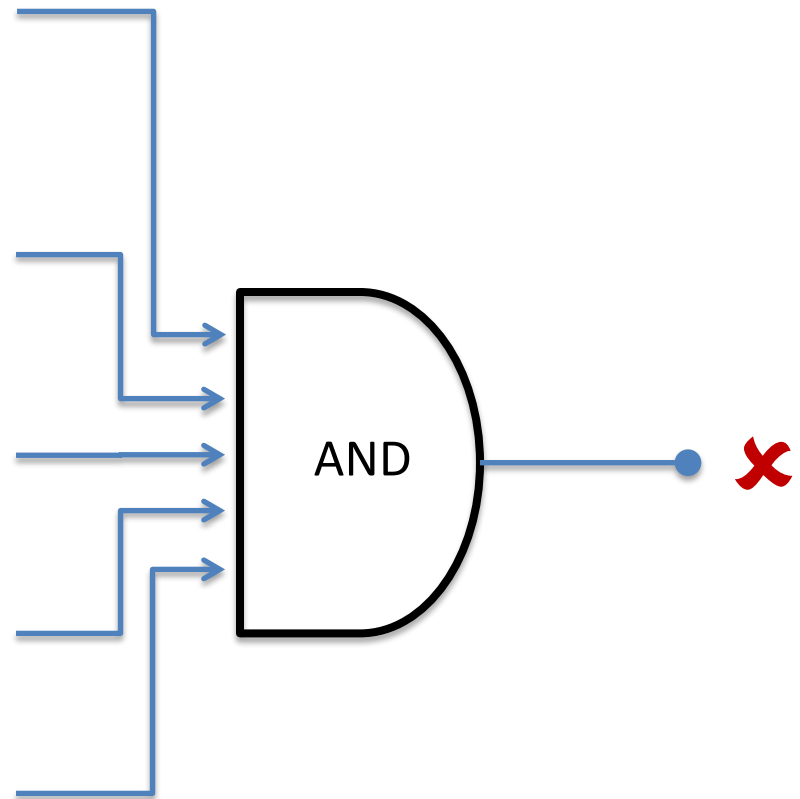

Level 1: Documenting the Problem

An OK2S standard plus interoperable real-time data sources would enable accurate reporting of compliance or non-compliance.

- Think of this in terms of:
 - Automated population of ISO11356 documents (and other data requirements, e.g., GlobalGAP), plus
 - A shared understanding of what constitutes compliance.
- A problem with this approach is that it can only identify a spray drift condition **once it has already happened**. Identifying issues is valuable and enables preventing them from happening again, but at that point any damage has already been done.

Level 2: Preventing the problem

There are two ways of looking at this:

- **Static:** *Use the precautionary principle to evaluate OK2S under worst-case conditions*
- **Dynamic:** *Evaluate OK2S under current conditions*

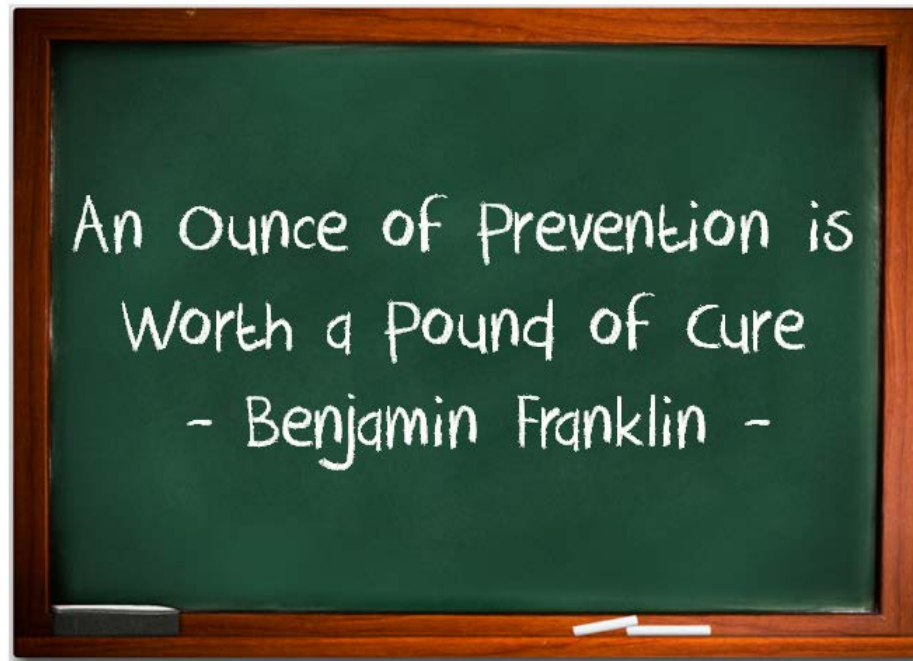

Level 2a: Preventing the problem statically



- OK to Spray + Precautionary Principle → Buffer zone
- Deliverable (in the form of buffer zones) is available during the planning stage
- Example: PAM. German project, supported by AEF. It automates buffer zone requests, generation, and delivery to the cab.

Level 2a: Preventing the problem statically



- Pro: Comparatively easy!
- Con: Restrictive, potentially inefficient, potentially too much, potentially too little!

Level 2b: Preventing the problem dynamically

*An **OK2S standard plus interoperable real-time data sources** would also enable **real-time OK2S evaluation** and the ability to **prevent noncompliance by suspending product application** under inadequate conditions.*



How dynamic prevention could work

Wind speed: Low
OK to Spray = True

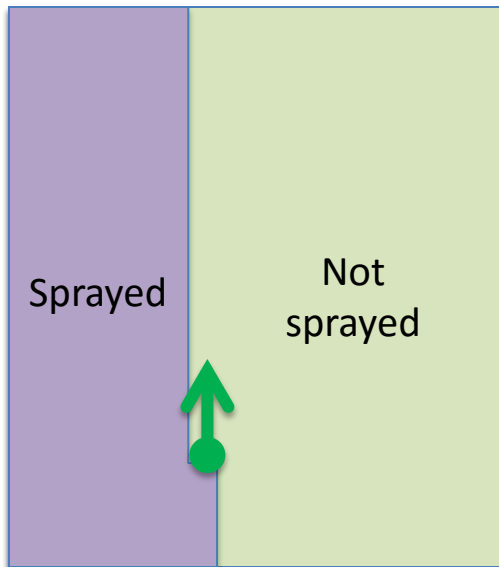

- Conditions good:
OK to Spray = True

Wind speed: High
OK to Spray = **FALSE**

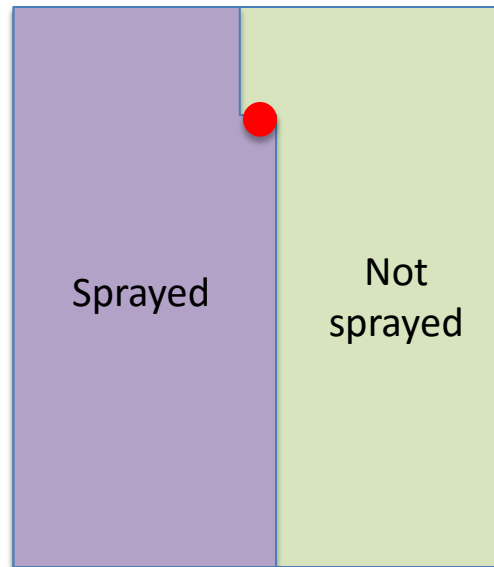

- Spraying must
pause while
conditions are bad.

Wind speed: Low
OK to Spray = True

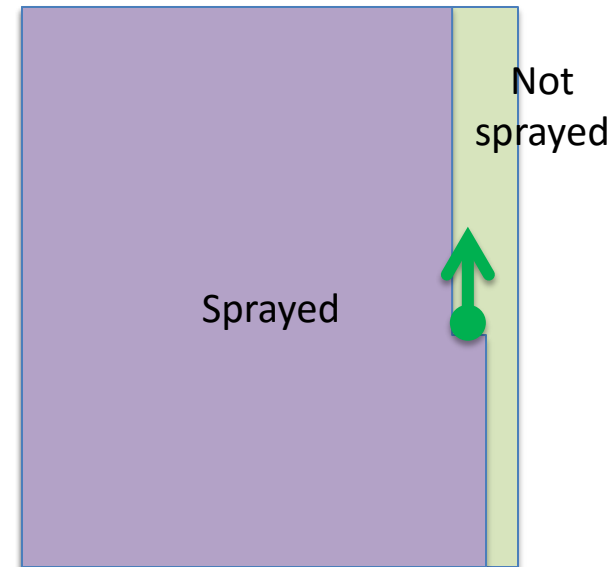

- Spraying resumes
when conditions
are good again.

Costly, but grower is protected

Level 3: Managing the problem

*An **OK2S standard** plus **interoperable real-time data sources** could enable machinery to **dynamically adapt** to changing conditions to **remain OK2S** under a wider set of conditions.*

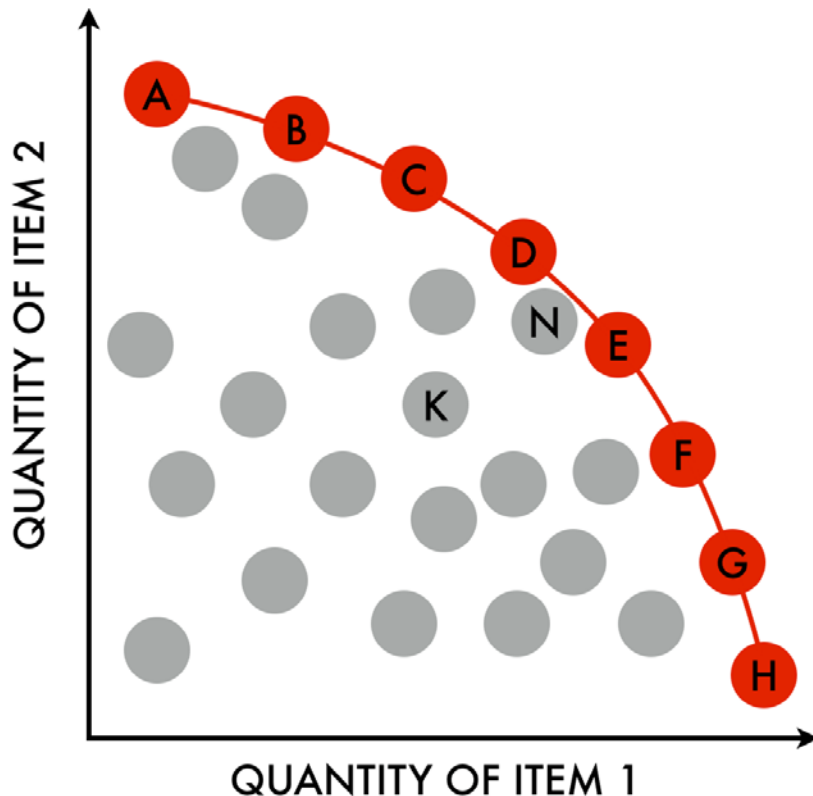

Multi-objective optimization problem, constrained by the need to remain OK to Spray at all times.

Optimization

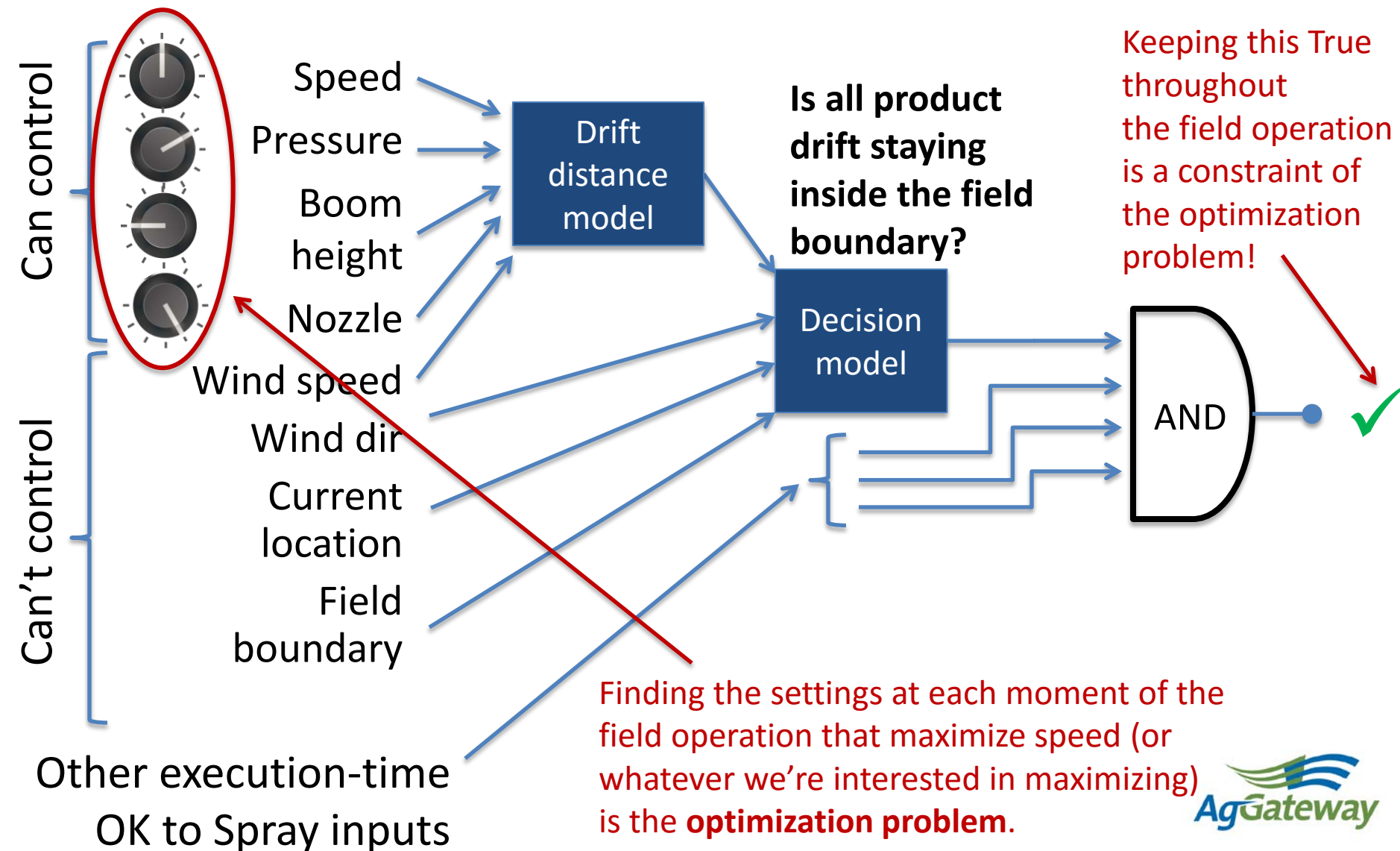

More about the optimization problem

- It's not OK to find any combination of “knobs” that will result in OK to Spray = True.
 - The grower or applicator has places to go and things to do... the solution needs to be optimal, i.e., the **best** “knob” settings that will get the task done the fastest, with the least cost, or according to whatever function we want to maximize.
- Finding optimal solutions “on the fly” can be challenging and computationally intensive.

The time is NOW

- Now is the time for standards development:
 - interoperability efforts are underway (AgGateway, AEF, etc.),
 - there is a large drift simulation modeling body of knowledge, and
 - some attempts are underway at bringing together the necessary technologies
- Yet drift is just one example:
 - standardized field operations parameters, data analysis, and reporting methods will enable more trusted data collection and regulatory reporting, as well as more principled decisions by all parties involved in agriculture.

Summary

- Regulatory pressure and record-keeping requirements are increasing for growers and applicators.
- A lack of interoperability makes it difficult to comply.
- The combination of mounting pressure and lack of interoperability can lead to grower/applicator inadvertently being out of compliance.
- The OK to Spray (and OK to Apply / OK to Proceed) concepts arose out of the desire to make it easier to communicate compliance requirements / conditions.
- OK to Spray can be combined with real-time data sources and interoperability to provide various forms of management for field operations, ranging from accurate records of the task performed, to dynamic real-time management during the field operation.
- We need standards for OK to Spray and its components!



Questions?

